

UPOZORNĚNÍ

Úsek km 17,700-17,750 se nachází ve II. vnitřním ochr. pásmu prameniště Rožnov p. R.
– skladba vozovky viz. Vzorový příčný řez 4.3 (bez spojov. postříku)

Před zahájením zemních prací budou vytýčena veškerá podzemní vedení.
ZÁKRES INŽENÝRSKÝCH SÍTÍ V PŘÍČNÝCH ŘEZECH JE POUZE ORIENTAČNÍ !

Příčné řezy v místě křížení toku novou lávkou jsou podrobně rozkresleny
ve výkresové části jednotlivých mostních objektů.

C. STAVEBNÍ ČÁST

SO 101.3 - CYKLOSTEZKA

Souřadnicový systém JTSK Výškový systém Bpv

Zpracováno programem



PROJEKTANT	KONTROLA	ZODP.PROJEKTANT	Domovina - <i>ekologie, venkov, turistika, s.r.o</i> 793 15 Lichnov 147 Tel.: 554 643 155, 777 826 858 www.infodomovina.cz	
Ing. Gemela	Ing.Barandovski	Ing.Gemela	FORMÁT	
INVESTOR: Město Rožnov pod Radhoštěm, Masarykovo nám. 128/129, 756 61 Rožnov p. R.			DATUM	07/2008
			MĚŘÍTKO	1:100
STAVBA: Cyklostezka údolím Rožnovské Bečvy – Rožnov pod Radhoštěm			STUPEŇ	DSP+ZDS
			OBSAH: Charakteristické příčné řezy úsek km 17,000 - 17,750	ČÍSLO VÝKRESU

1 - KM 17.00000

Připojení na silnici č.III/48611

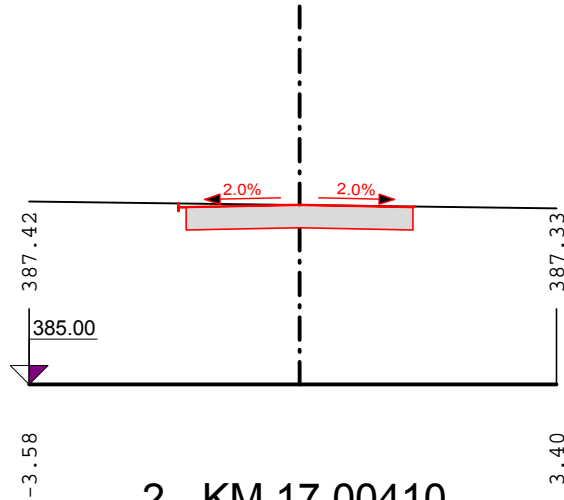

2 - KM 17.00410

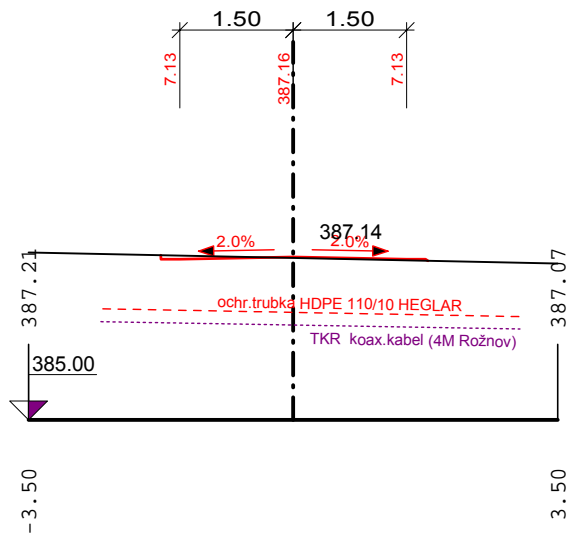

3 - KM 17.01160

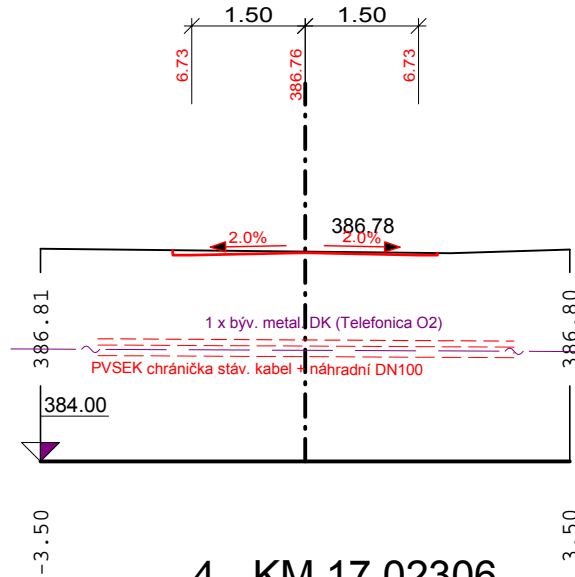

4 - KM 17.02306

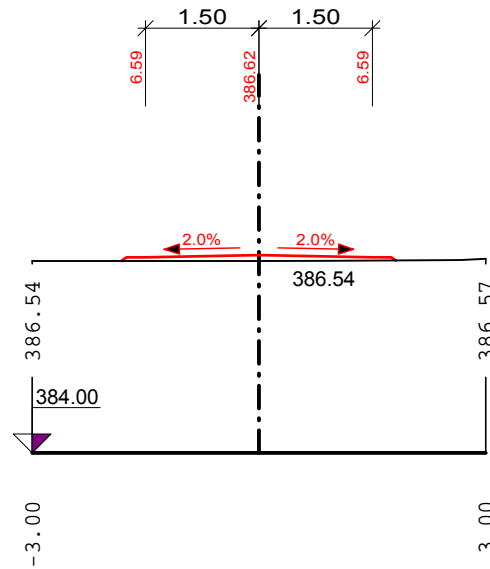

5 - KM 17.02625

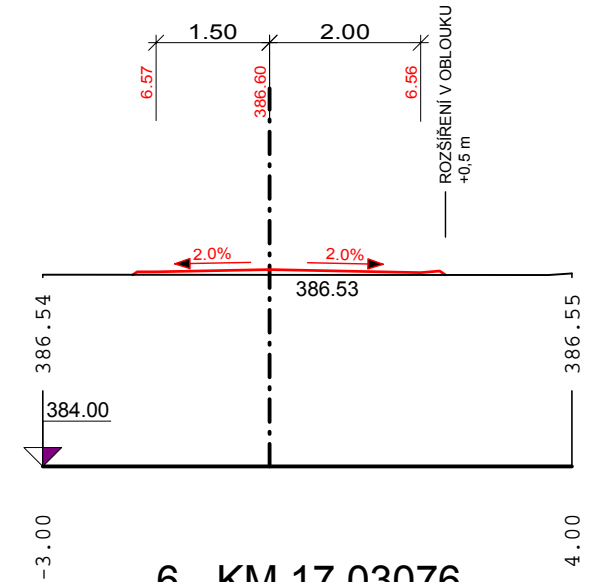

6 - KM 17.03076

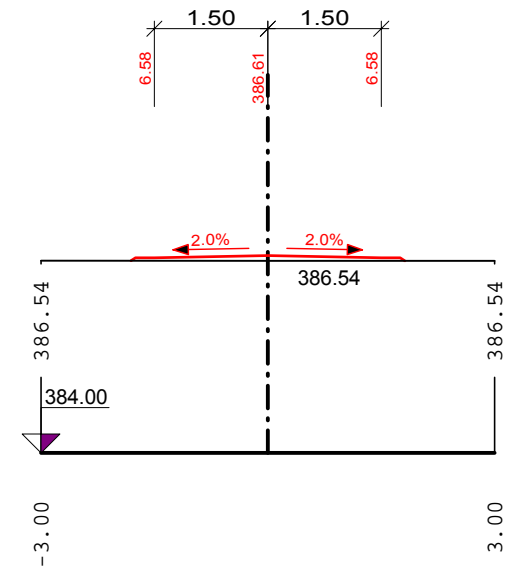

7 - KM 17.04500

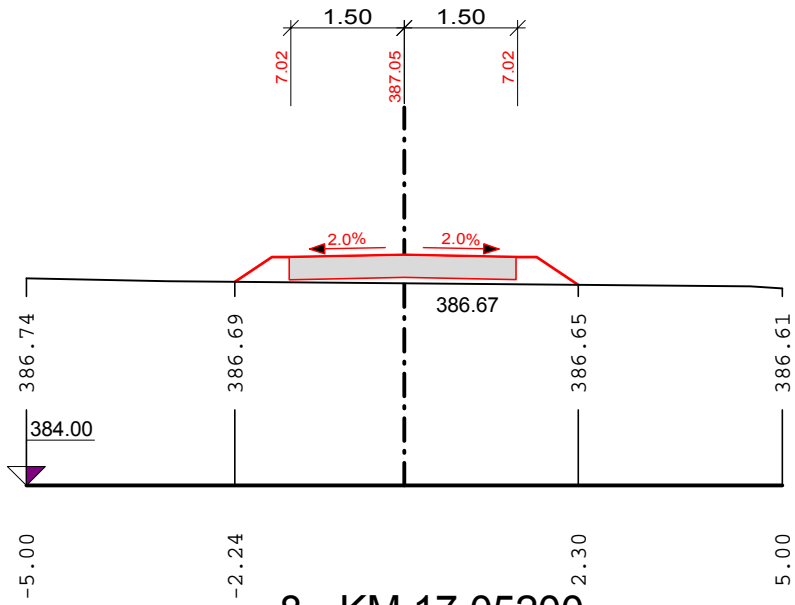

8 - KM 17.05200

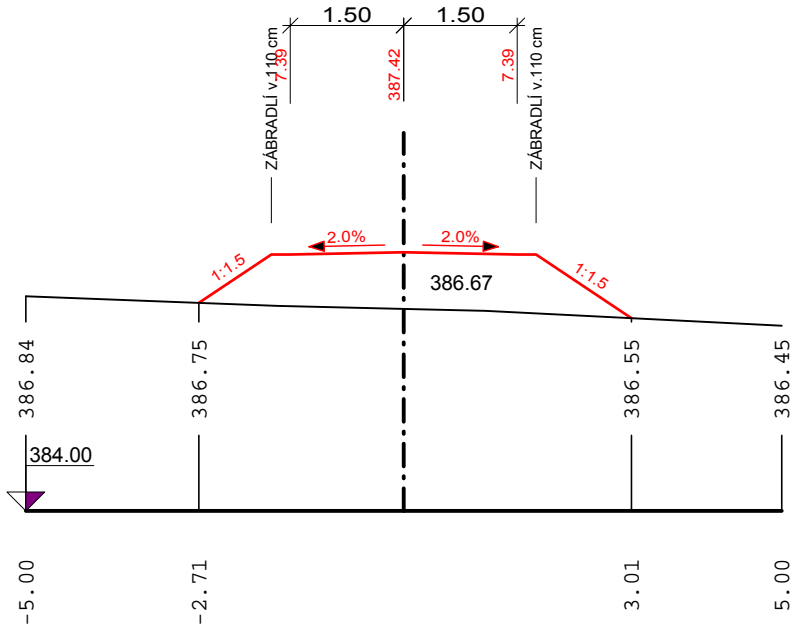

9 - KM 17.05868

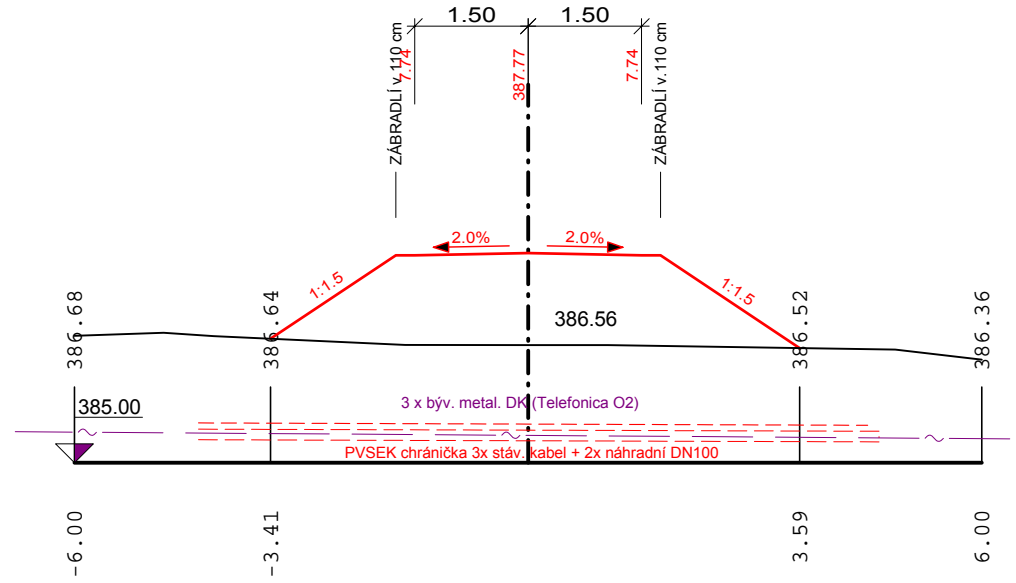

10 - KM 17.06410

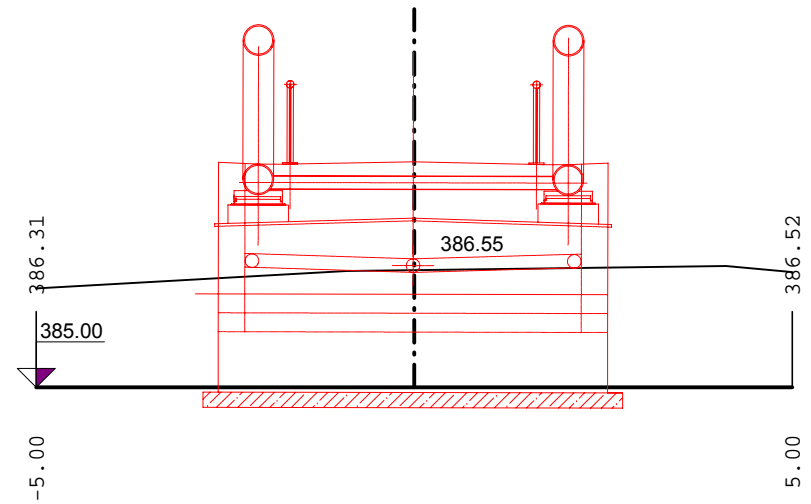

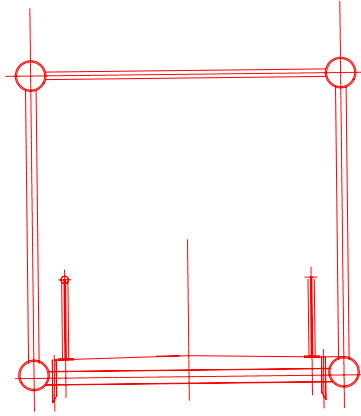

11 - KM 17.08510

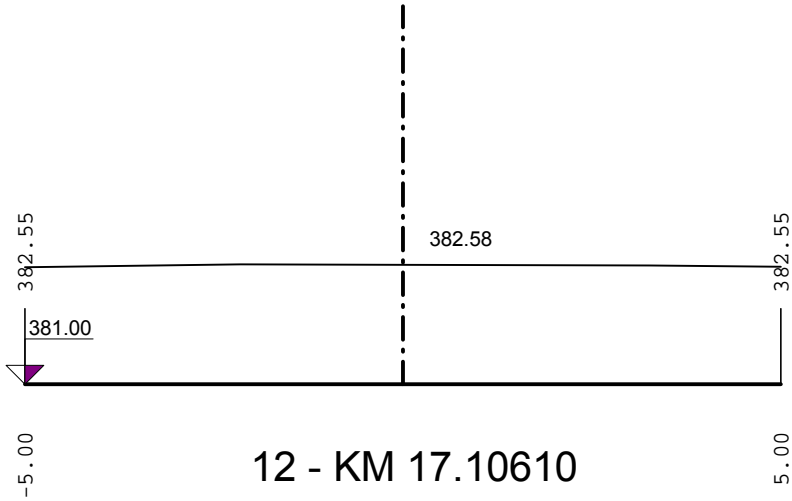

12 - KM 17.10610

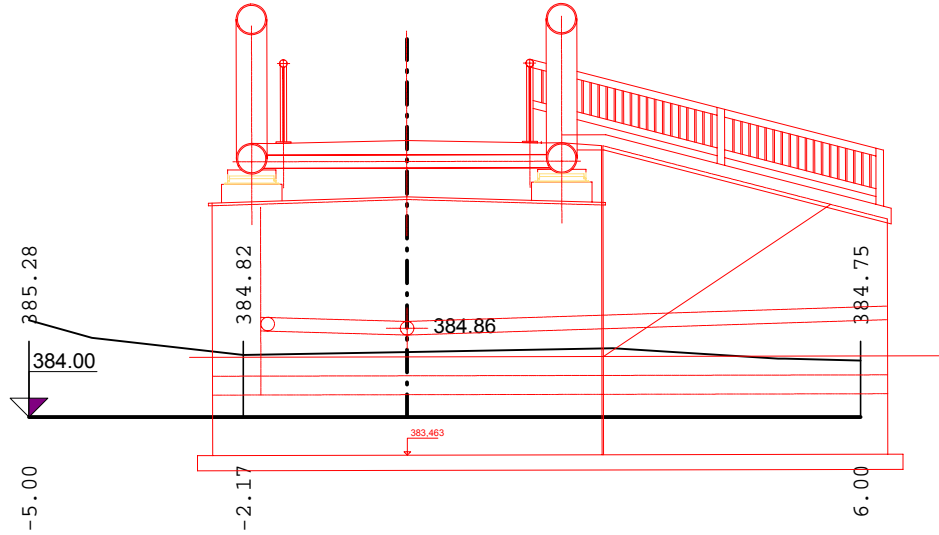

13 - KM 17.11057

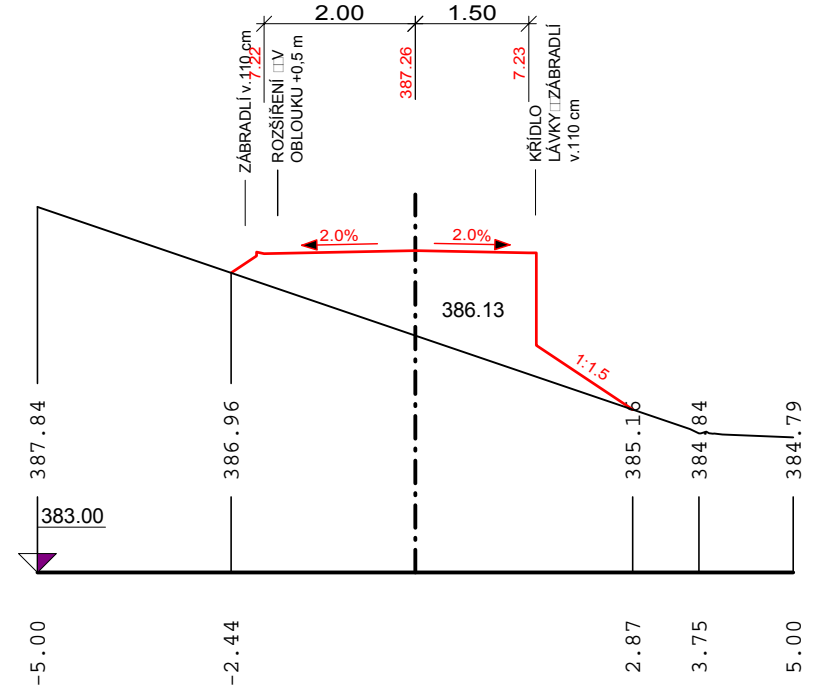

14 - KM 17.11700

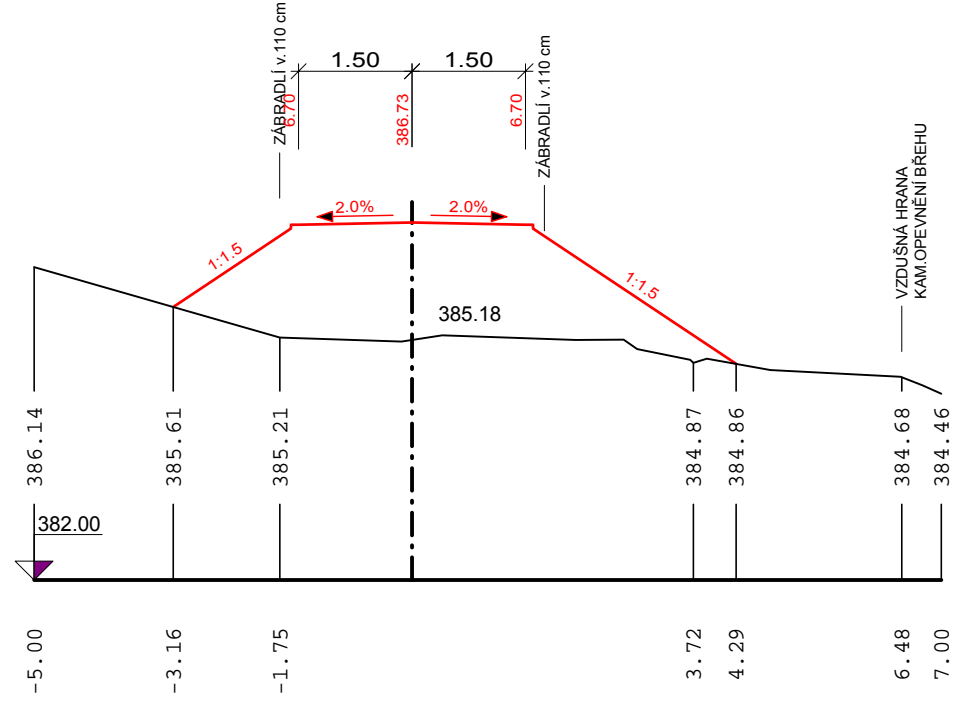

15 - KM 17.12262

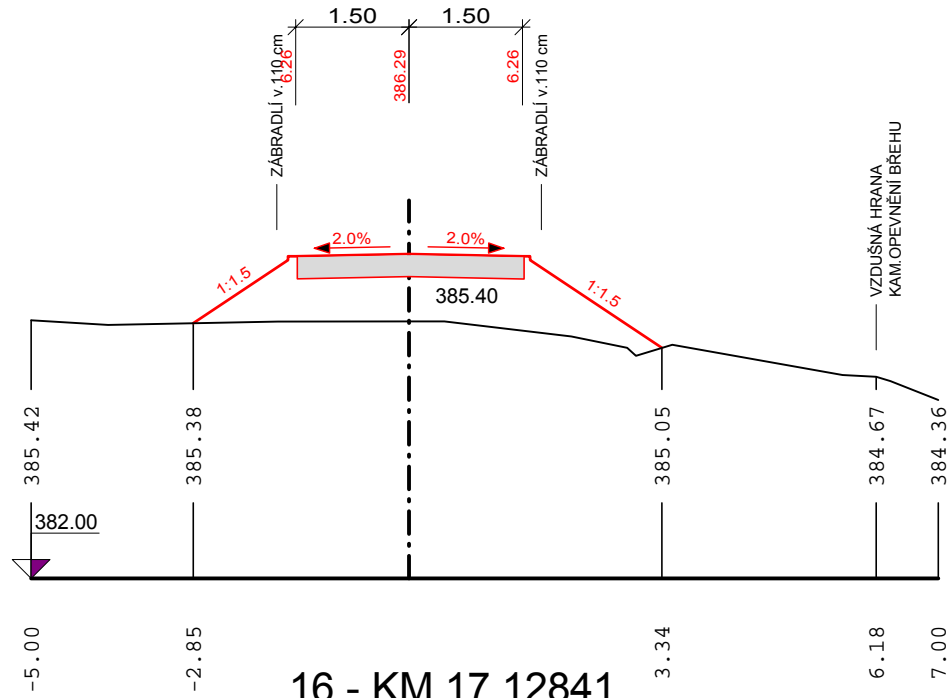

17 - KM 17.13395

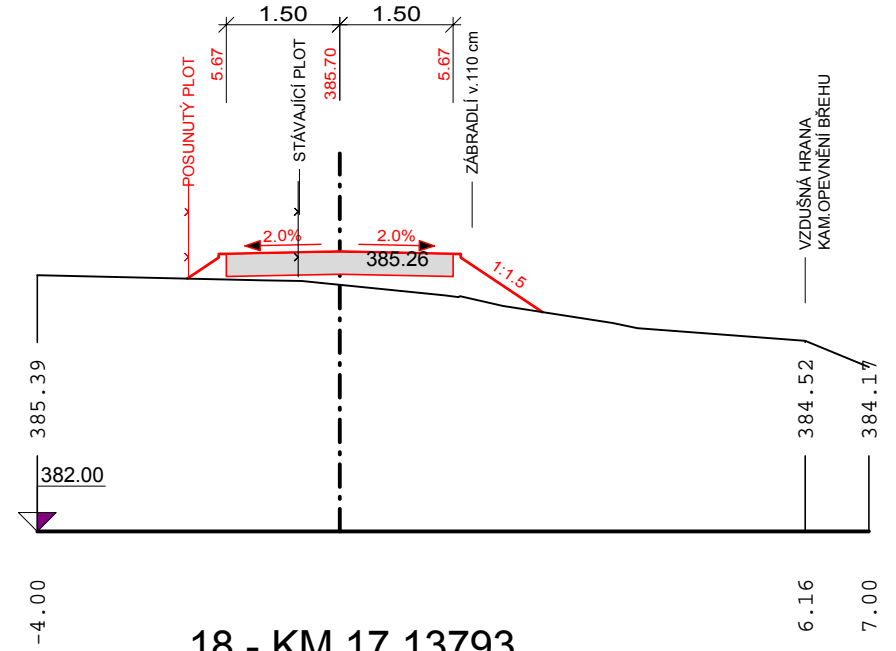

16 - KM 17.12841

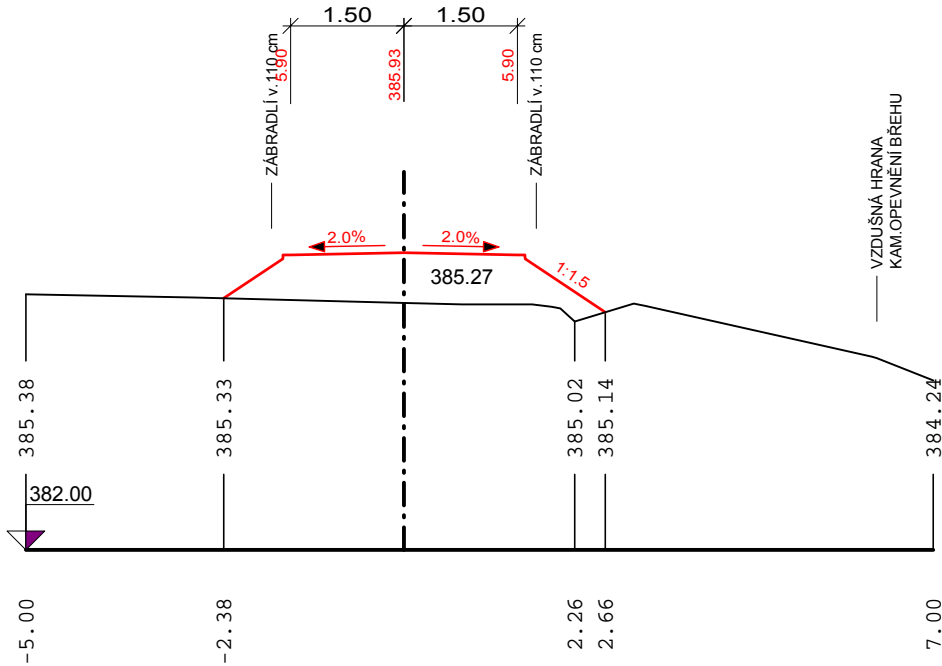

18 - KM 17.13793

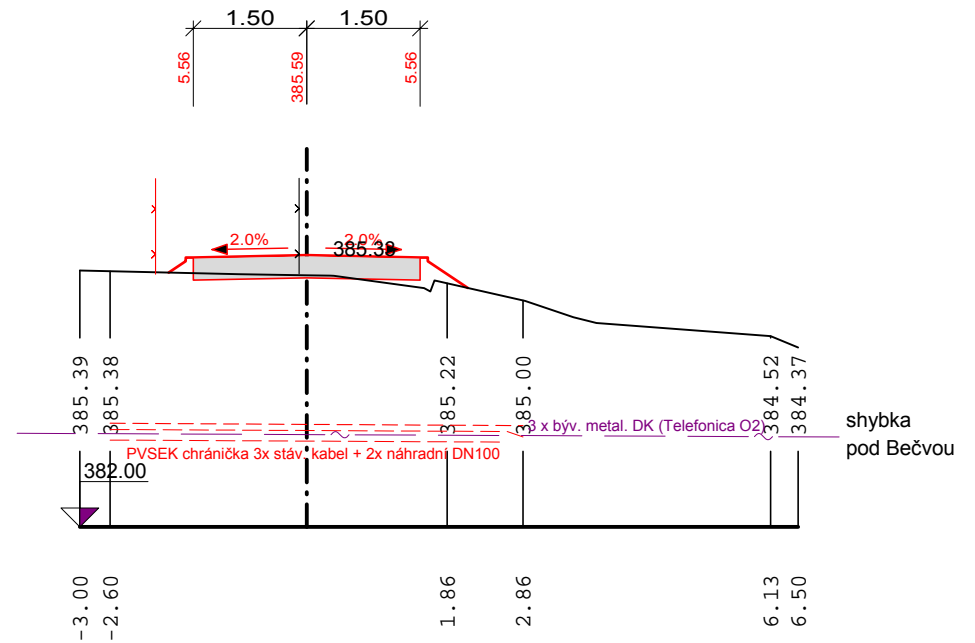

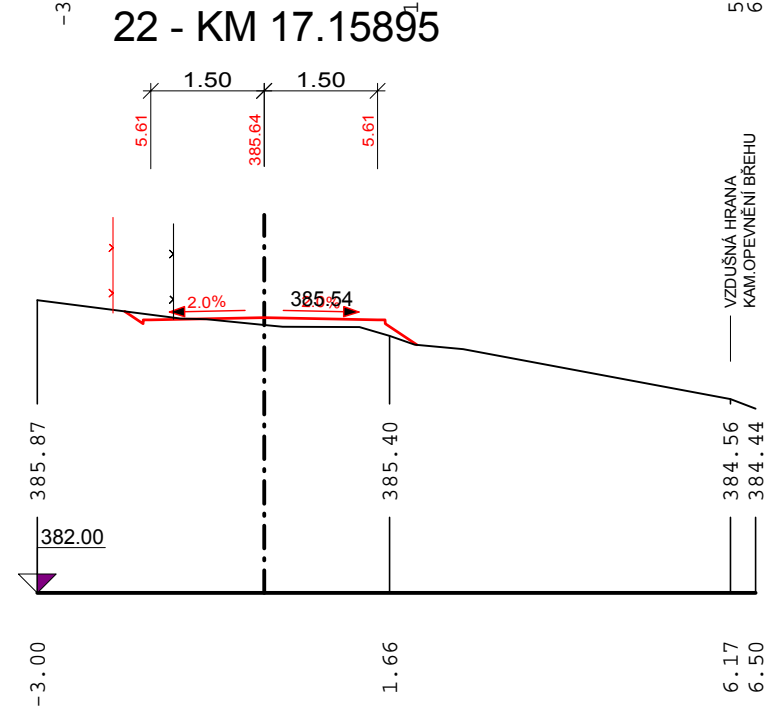
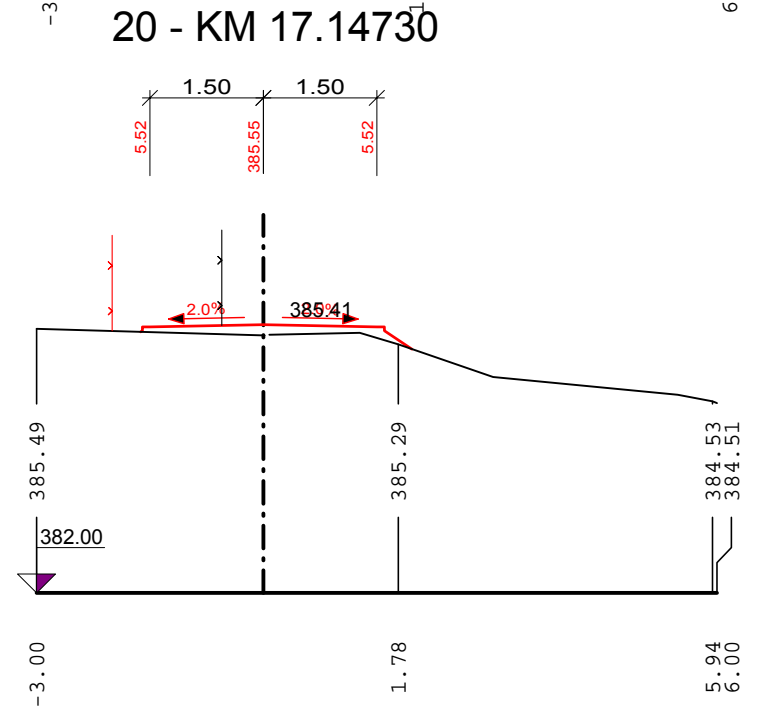
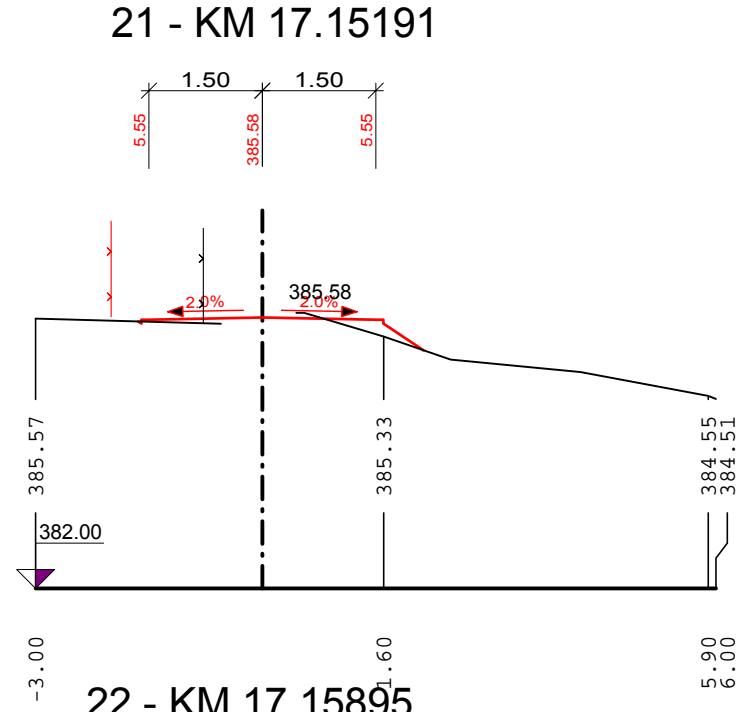
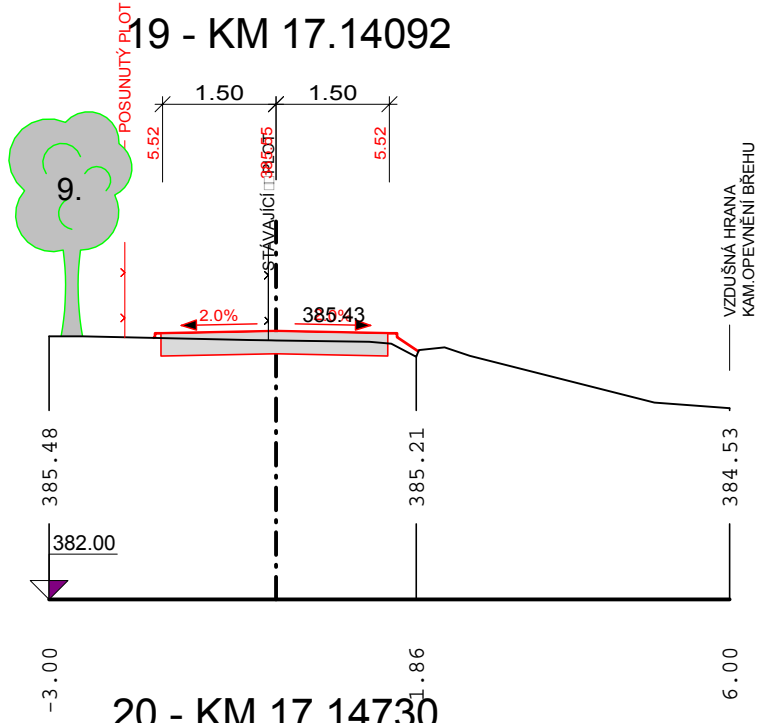

23 - KM 17.16646

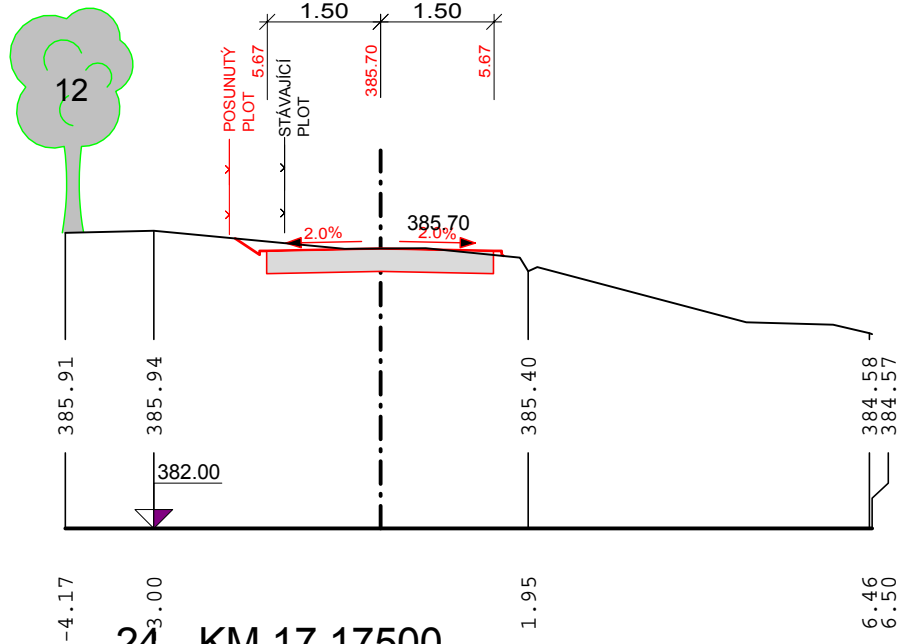

25 - KM 17.18300

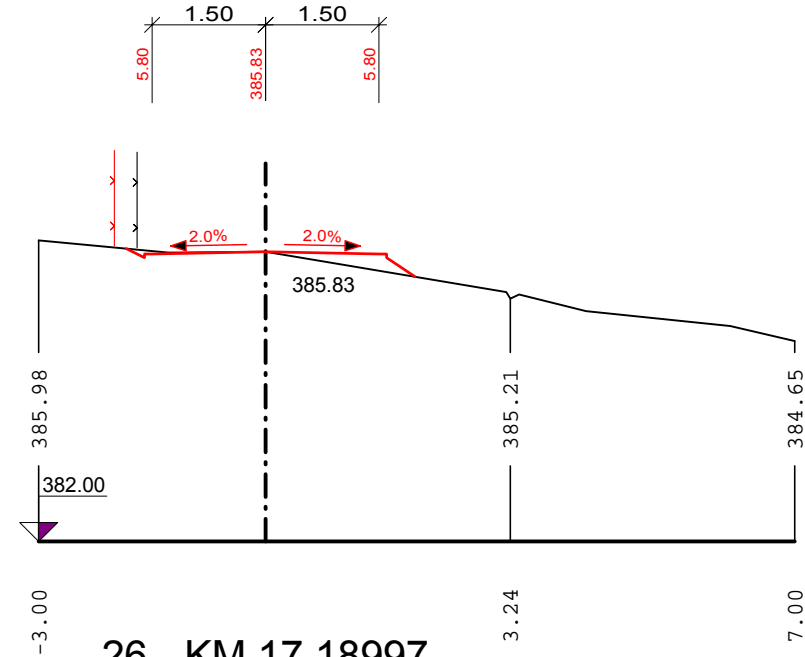

24 - KM 17.17500

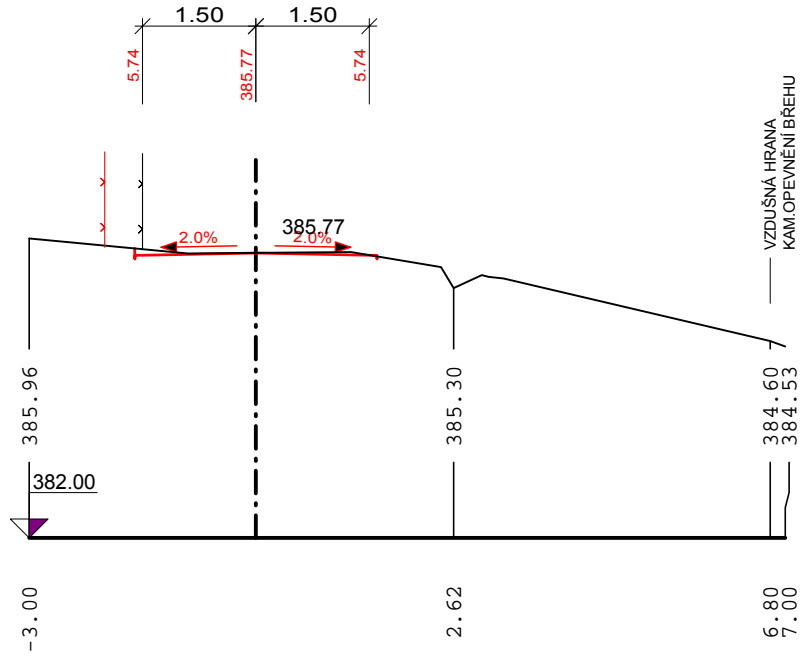

26 - KM 17.18997

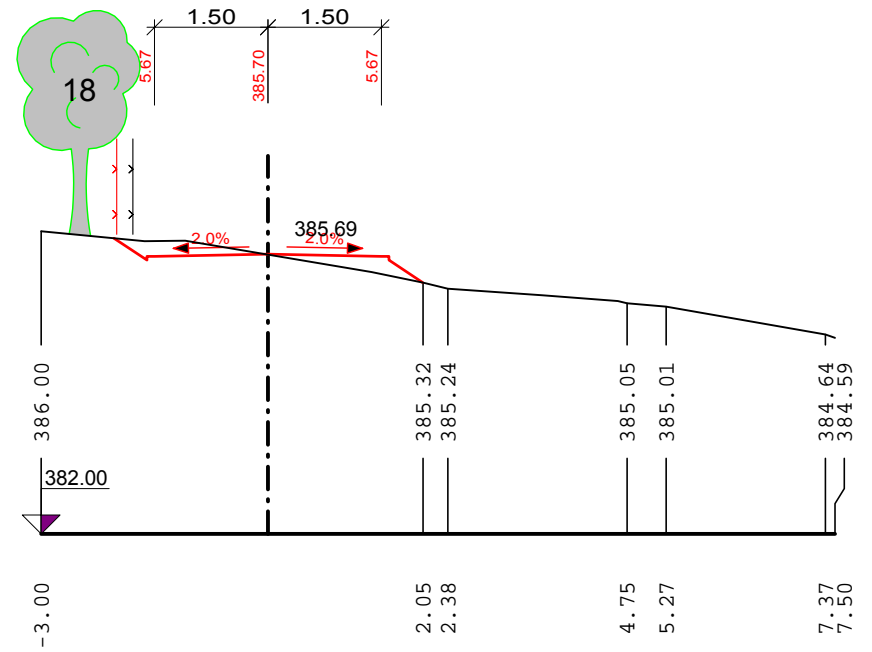

29 - KM 17.20800

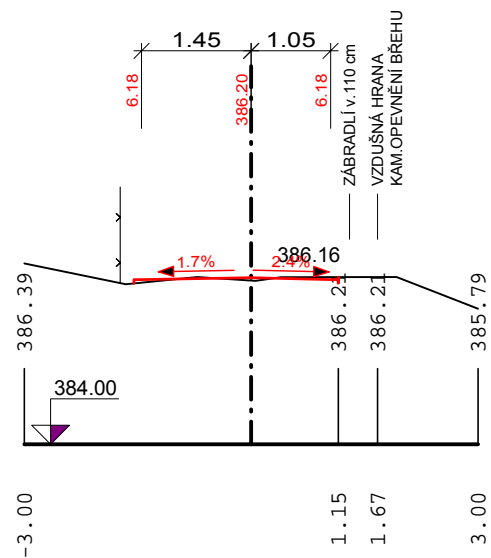
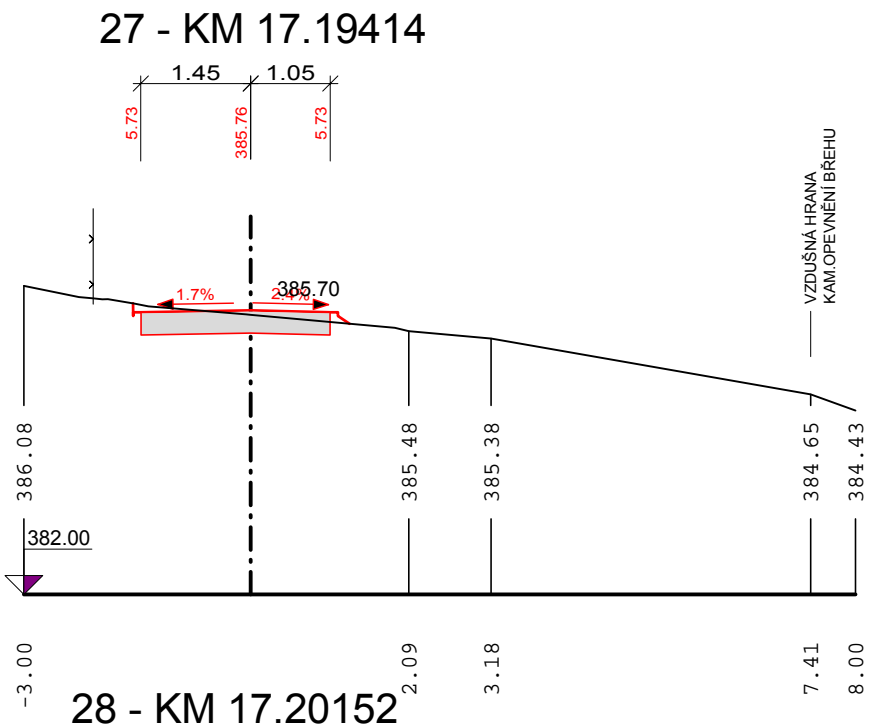

31 - KM 17.22200

28 - KM 17.20152

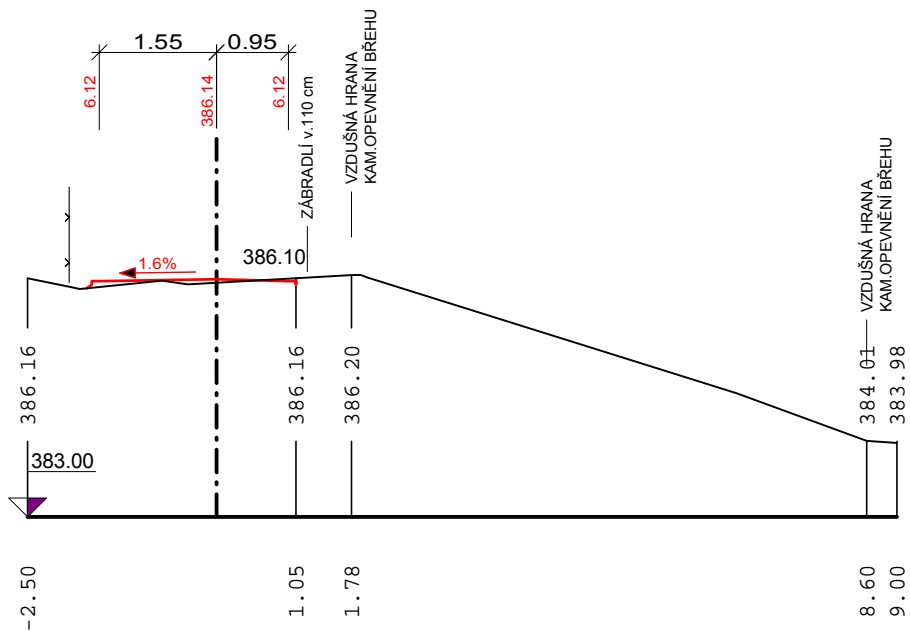

30 - KM 17.21442

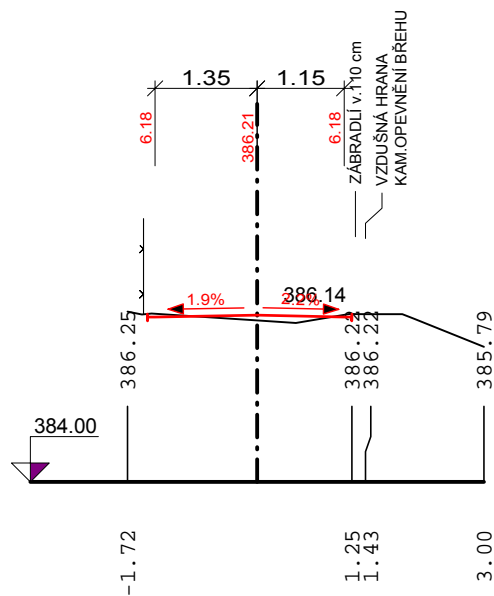

32 - KM 17.23000

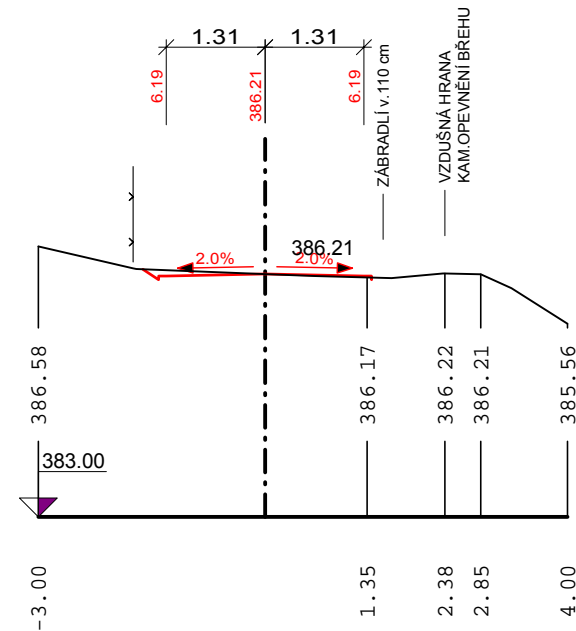

33 - KM 17.24000

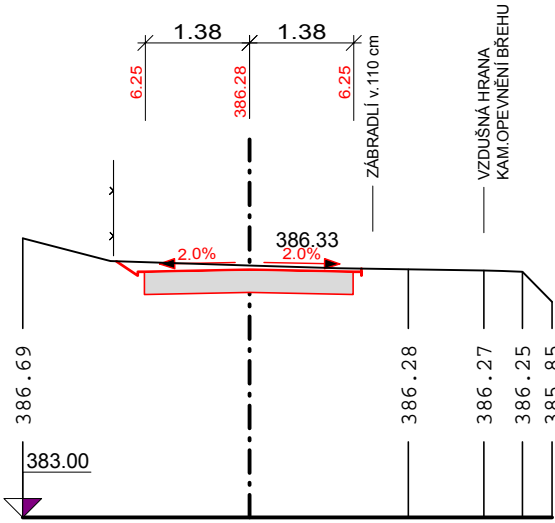

35 - KM 17.25445

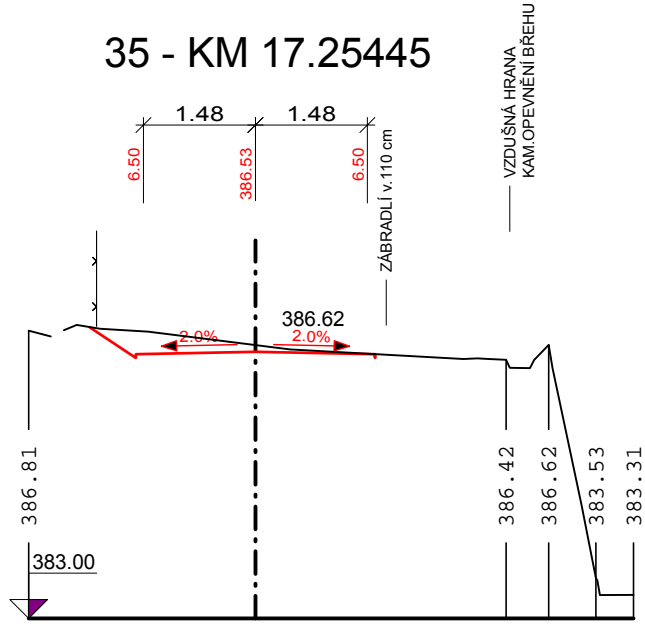

37 - KM 17.26820

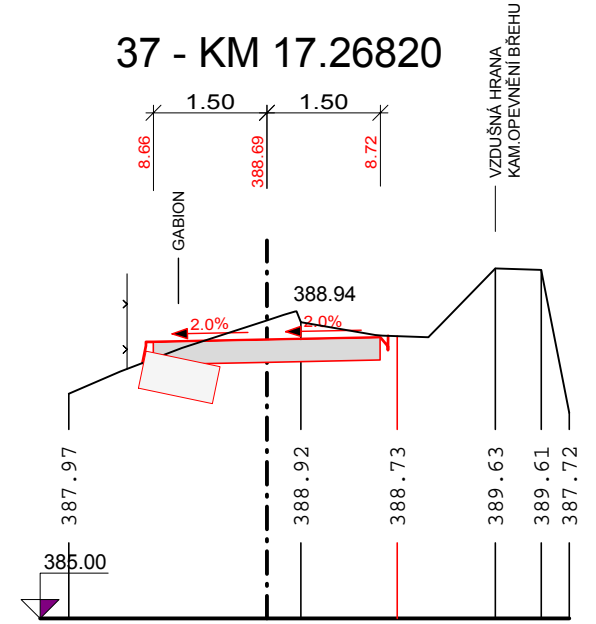

34 - KM 17.24975

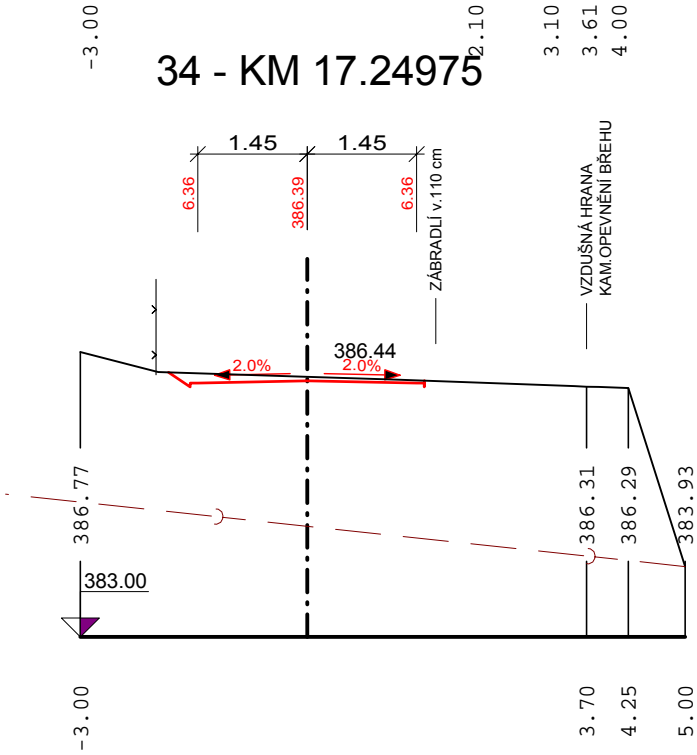

36 - KM 17.26094

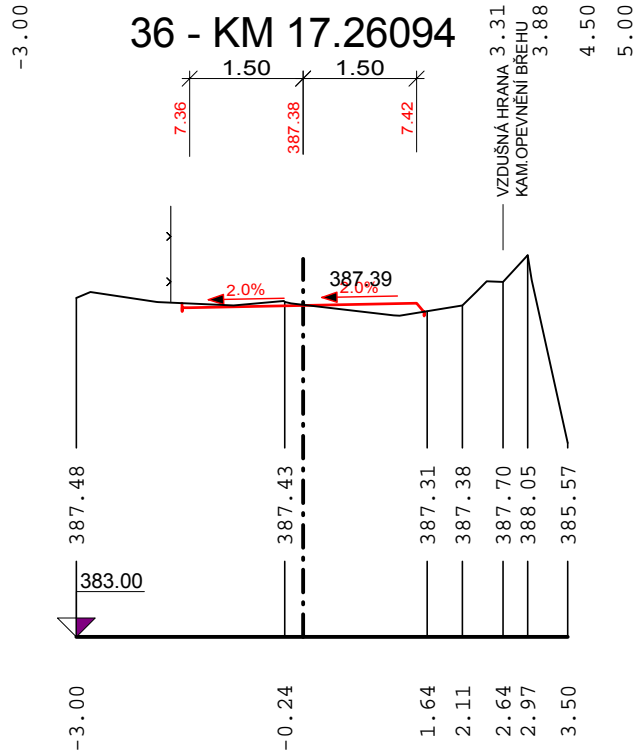

38 - KM 17.27200

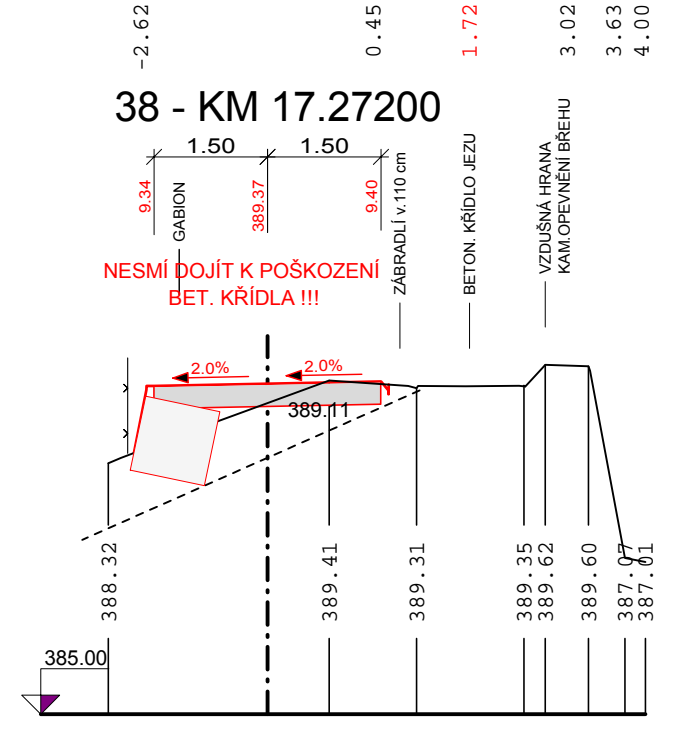

39 - KM 17.27828

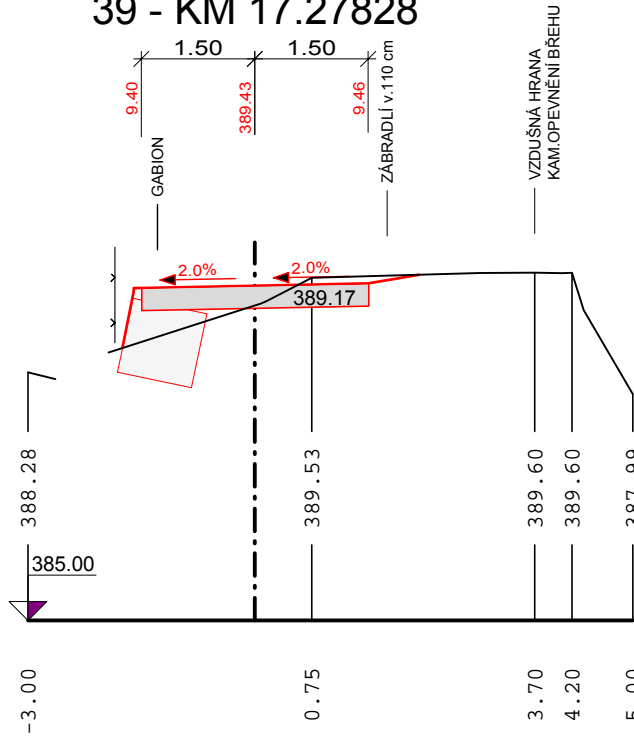

41 - KM 17.29600

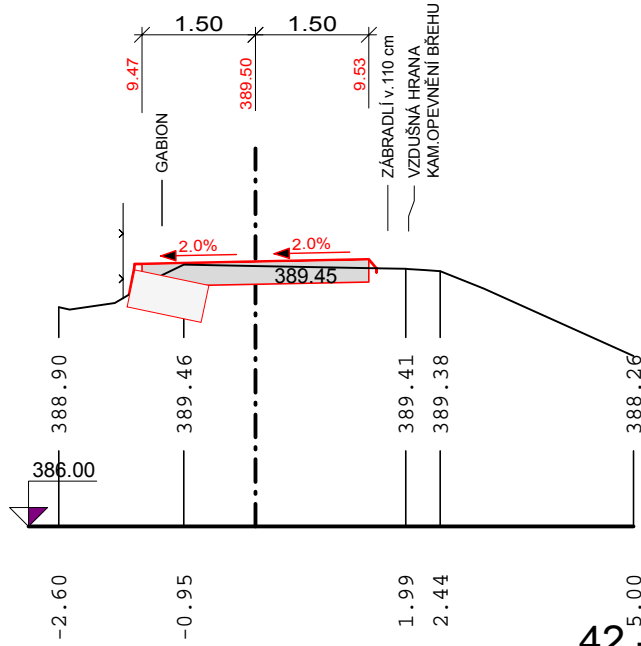

43 - KM 17.31040

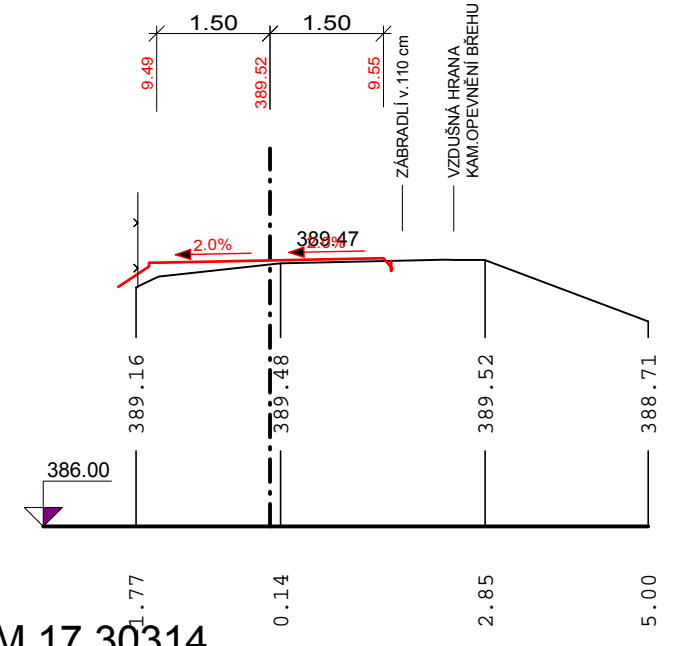

40 - KM 17.28600

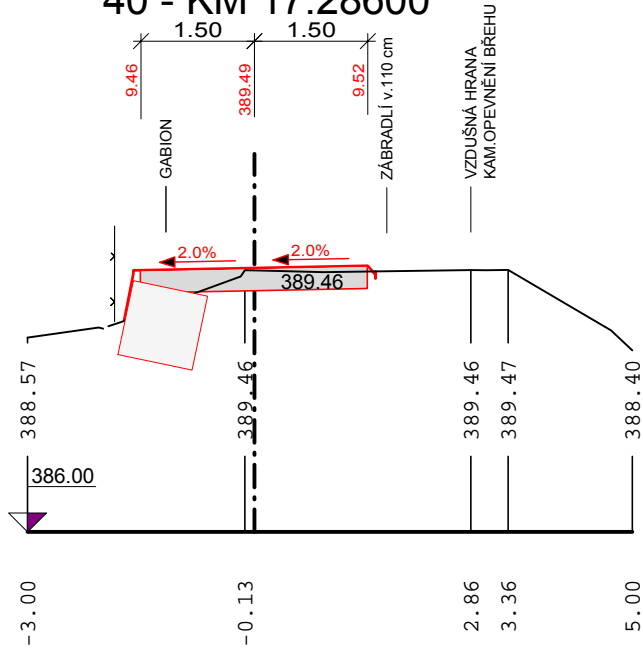

42 - KM 17.30314

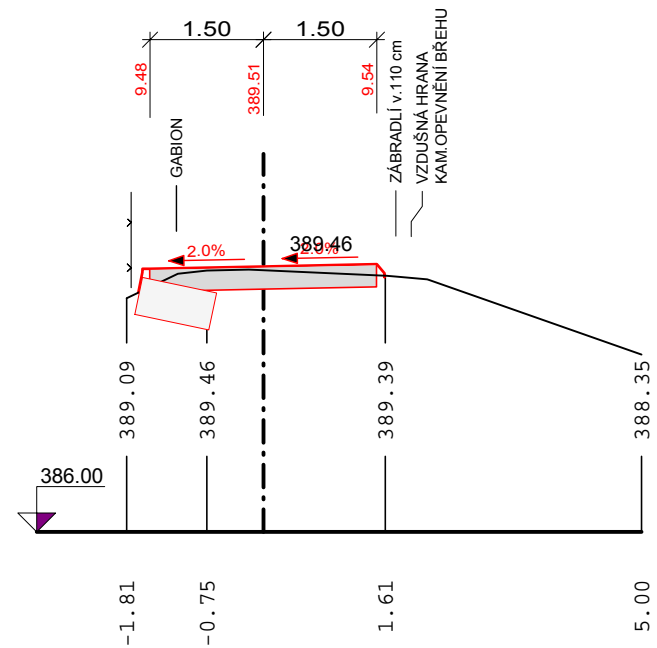

44 - KM 17.31557

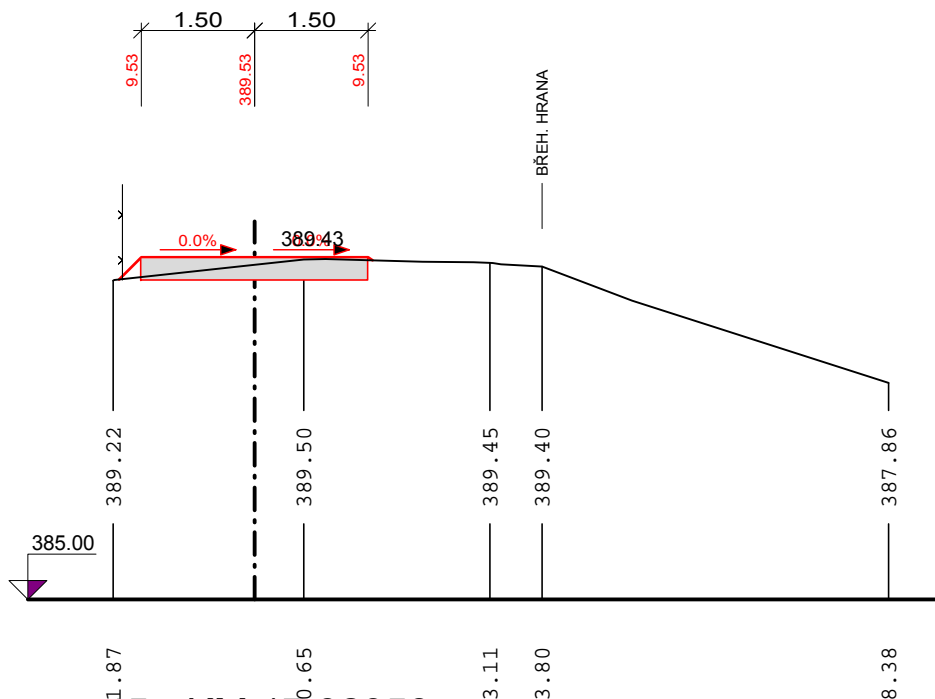

46 - KM 17.33200

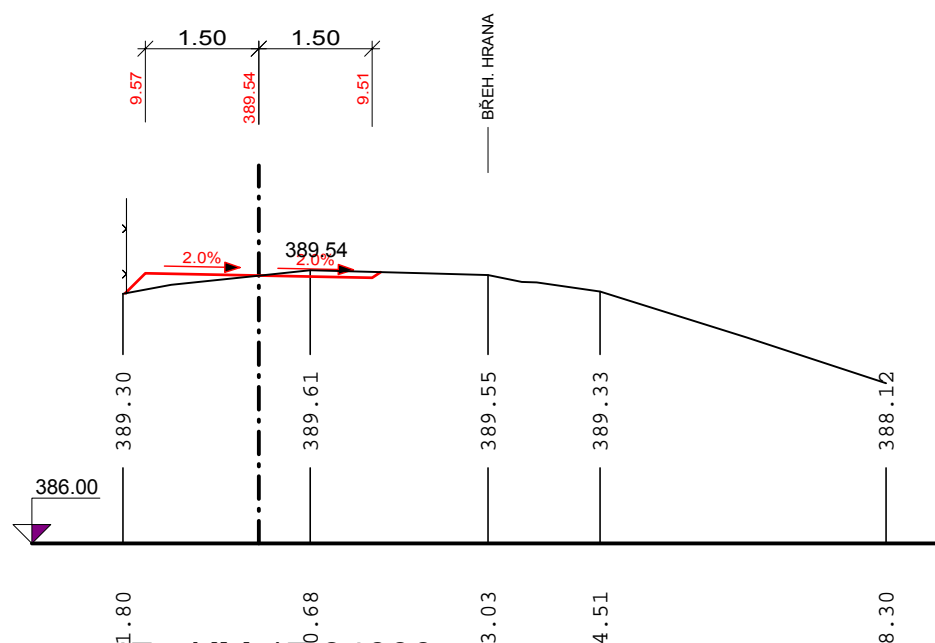

45 - KM 17.32358

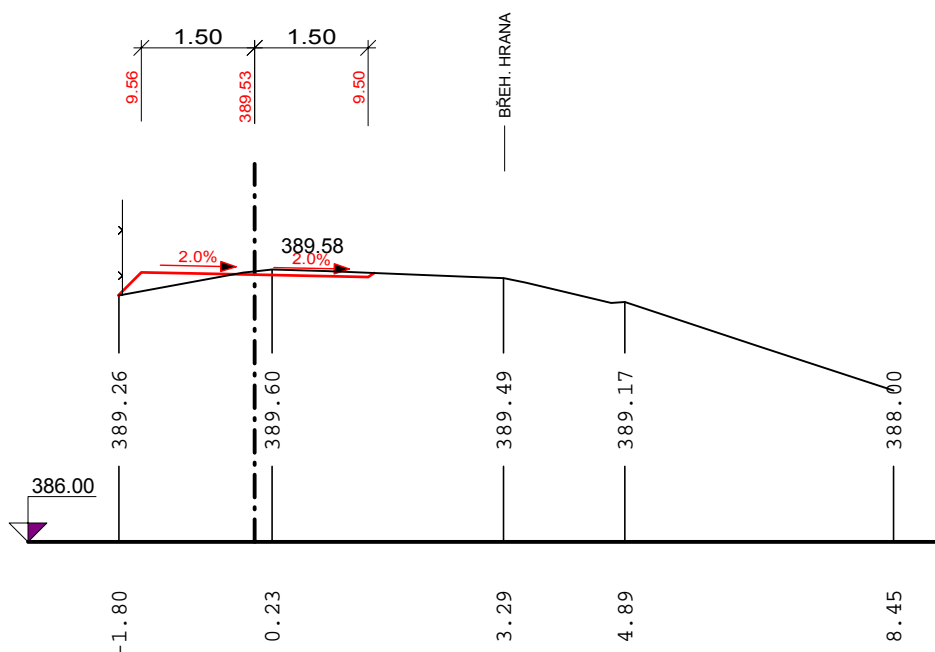

47 - KM 17.34000

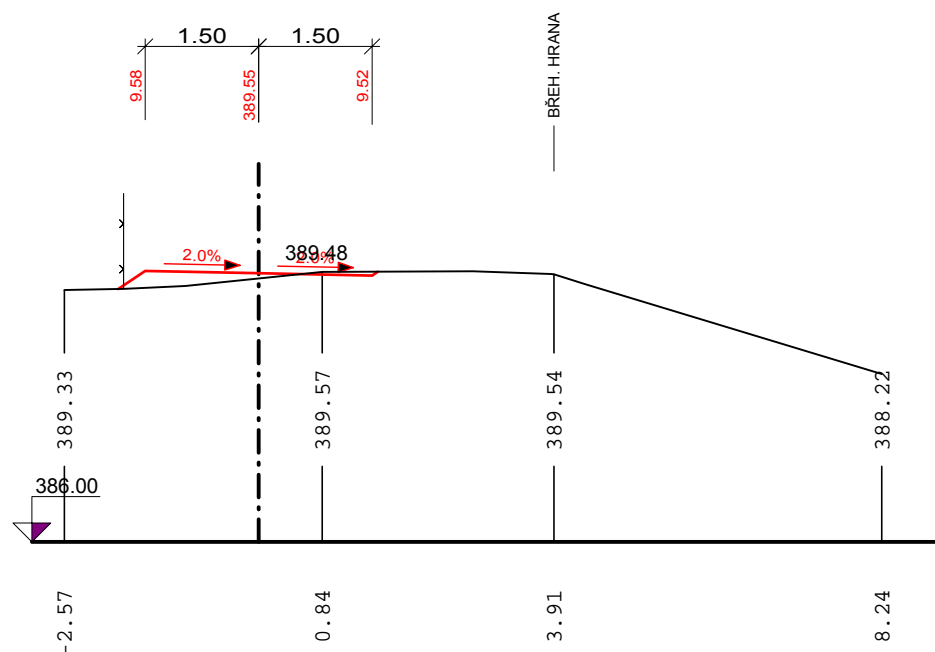

48 - KM 17.36000

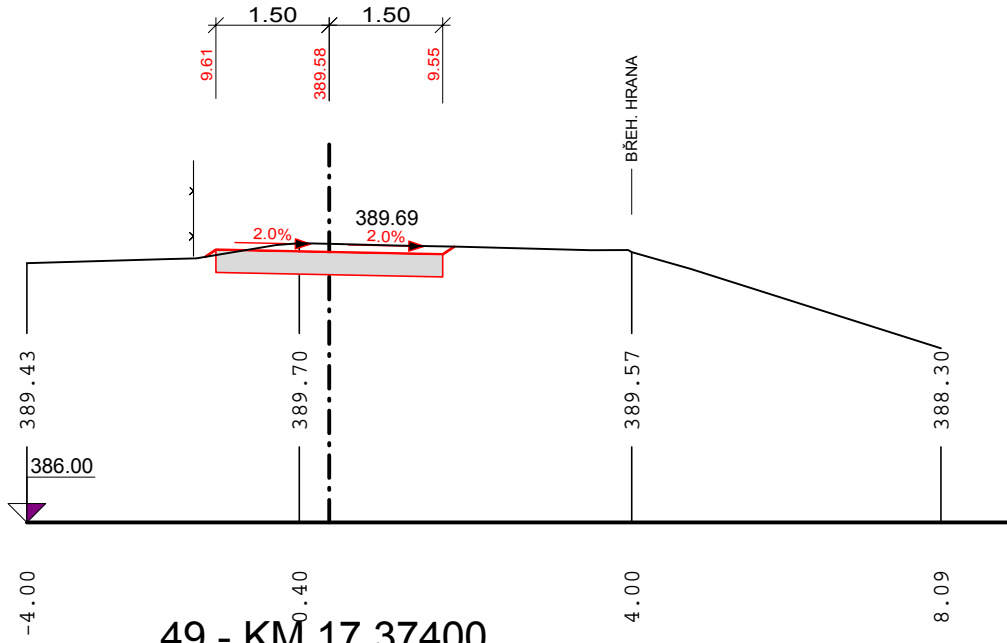

50 - KM 17.39000

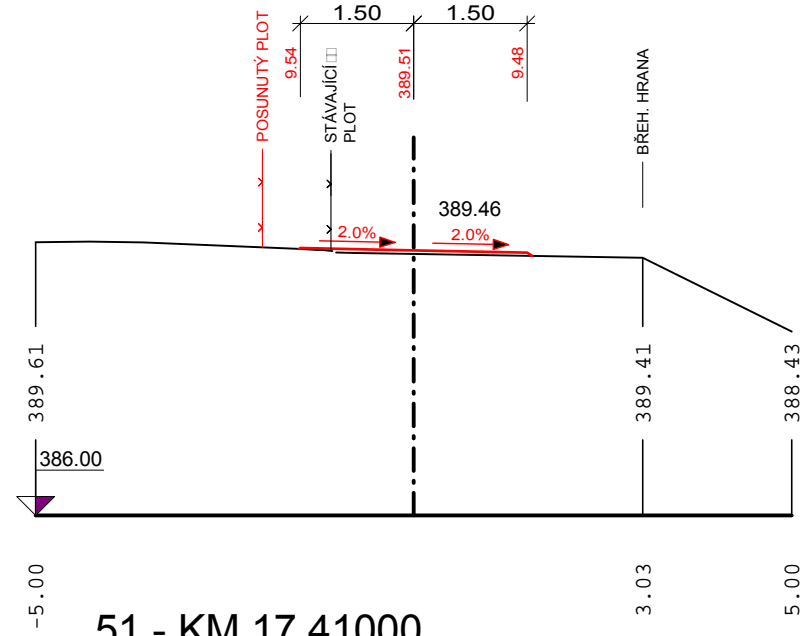

49 - KM 17.37400

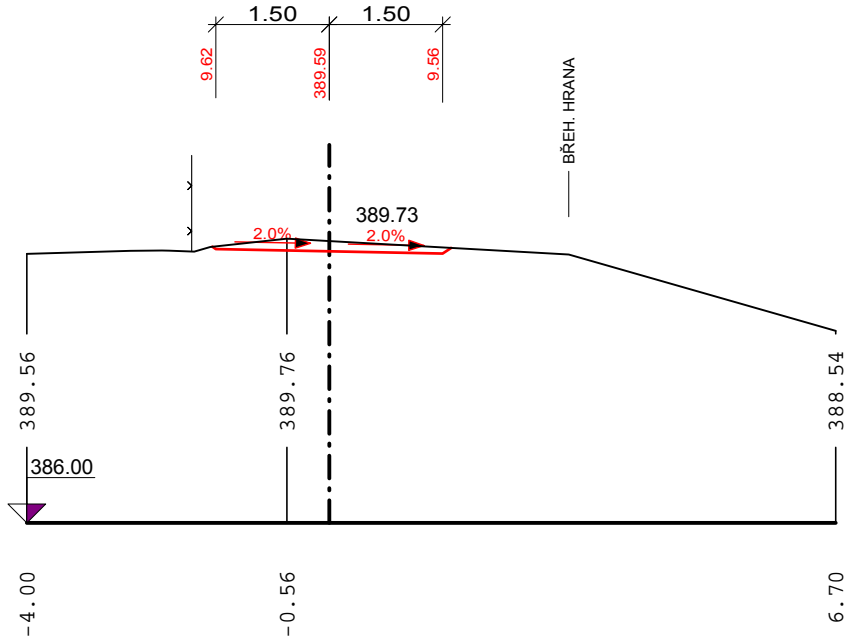

51 - KM 17.41000

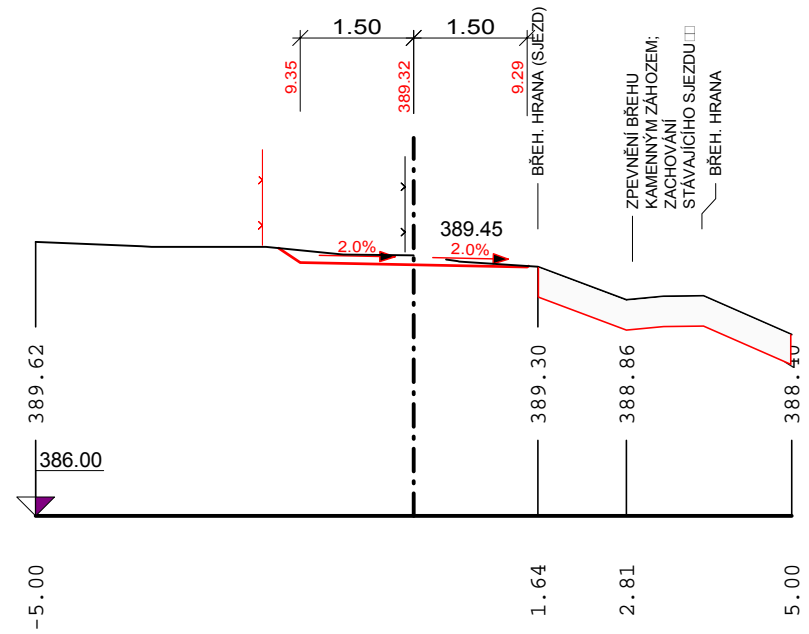

52 - KM 17.43000

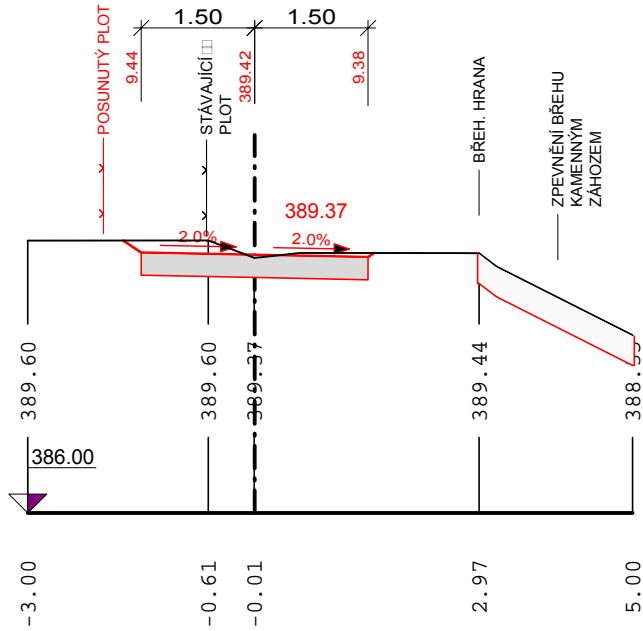

54 - KM 17.48000

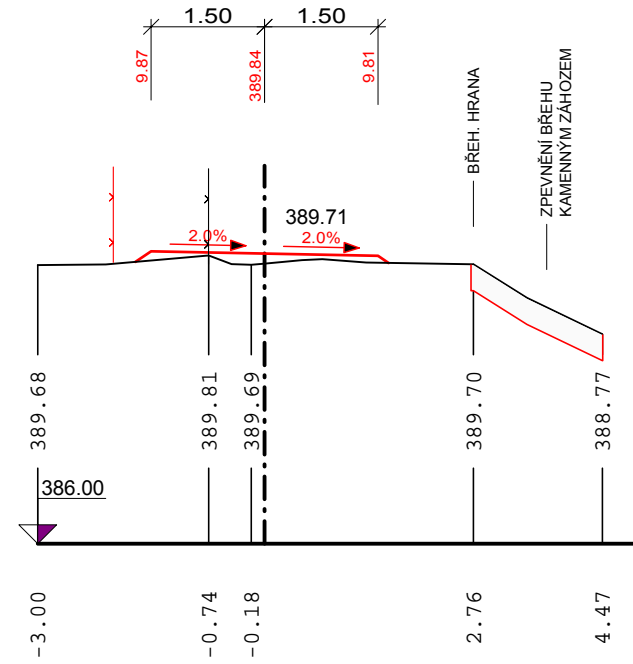

53 - KM 17.45500

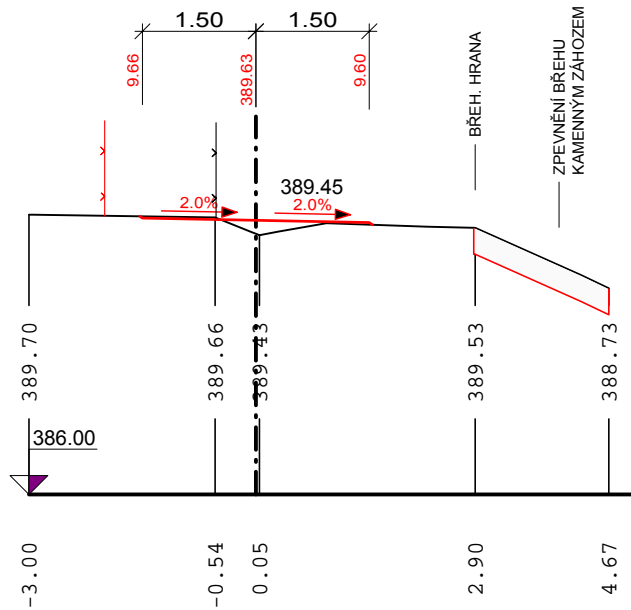

55 - KM 17.51000

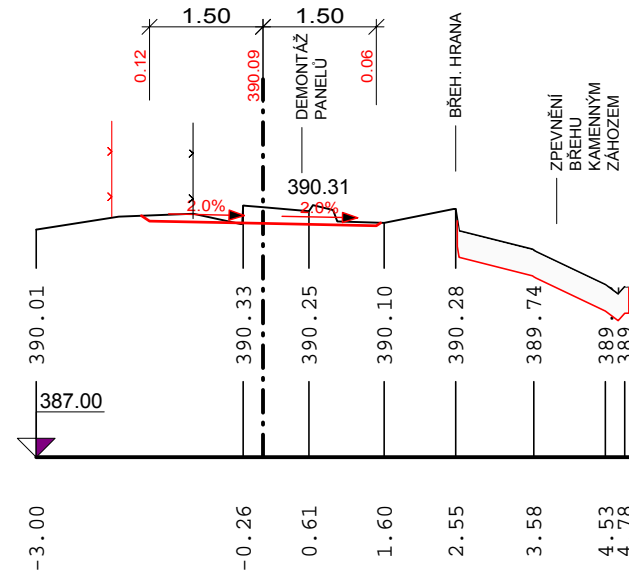

58 - KM 17.56950

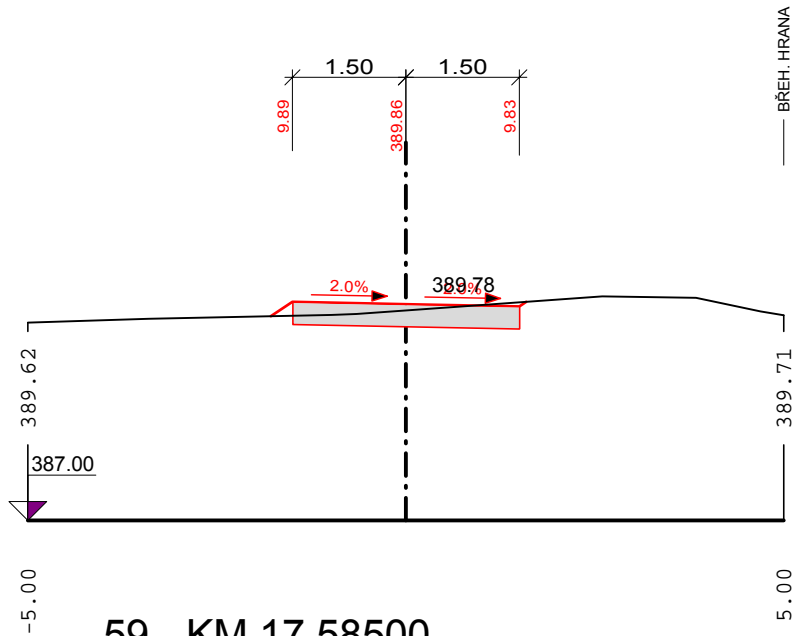

60 - KM 17.60000

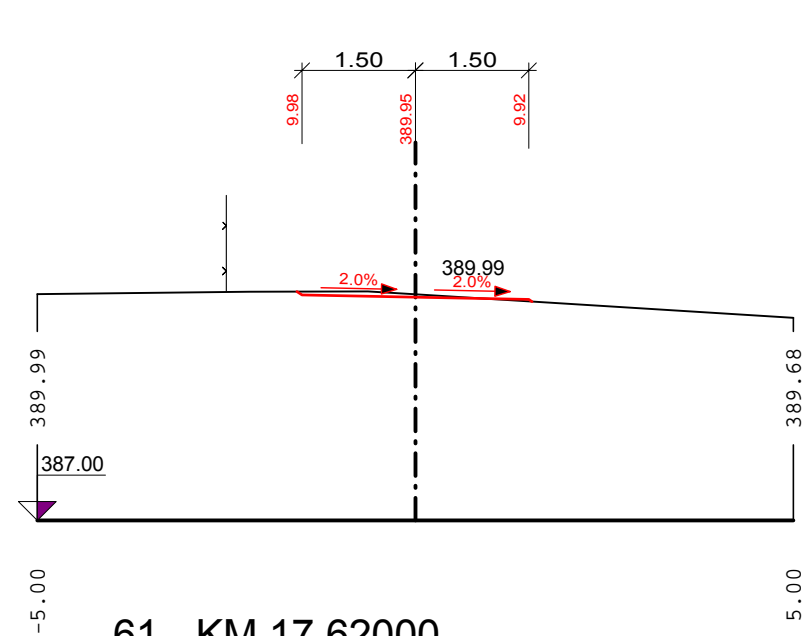

59 - KM 17.58500

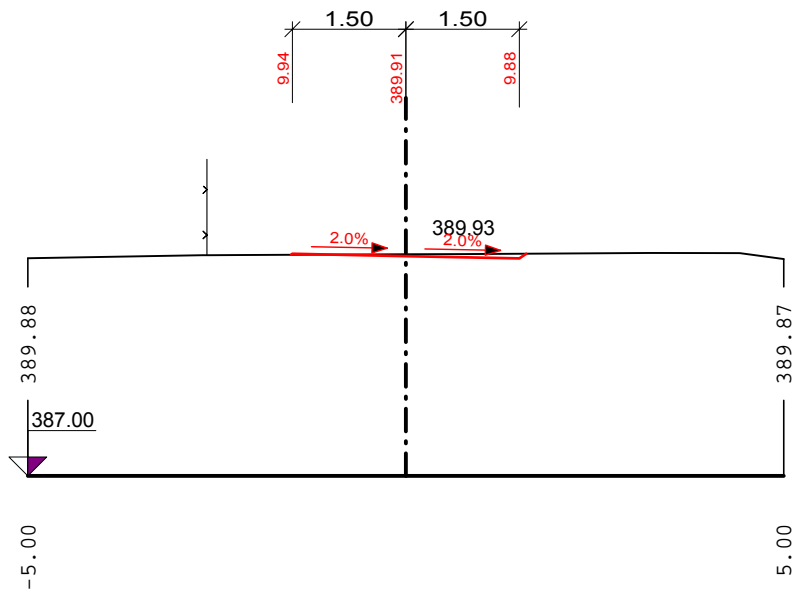

61 - KM 17.62000

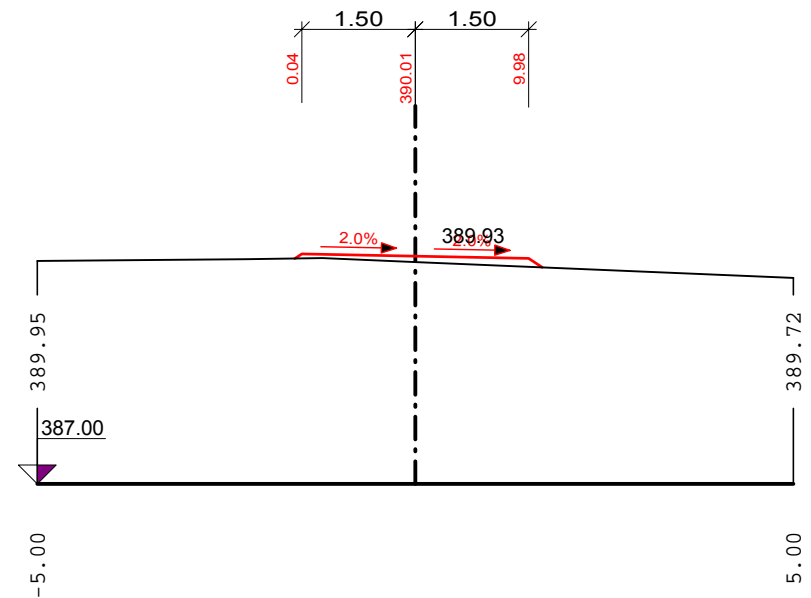

62 - KM 17.64000

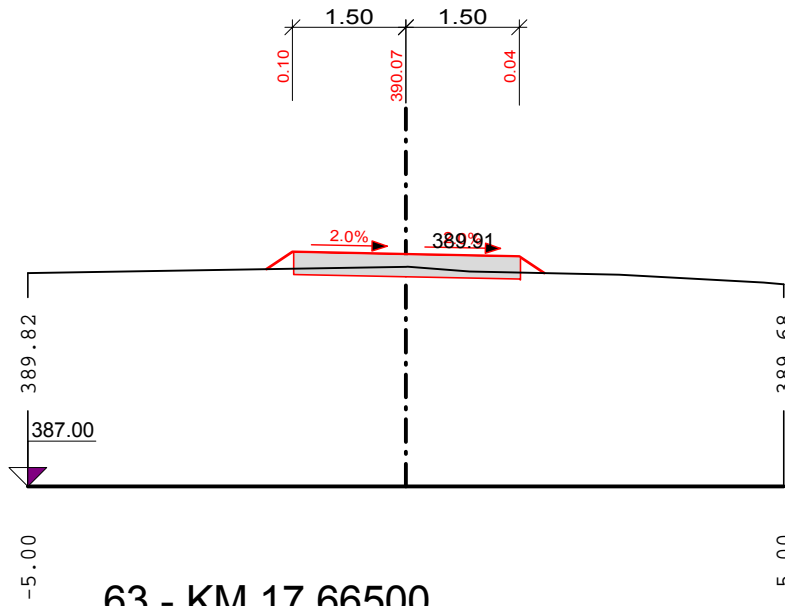

64 - KM 17.68600

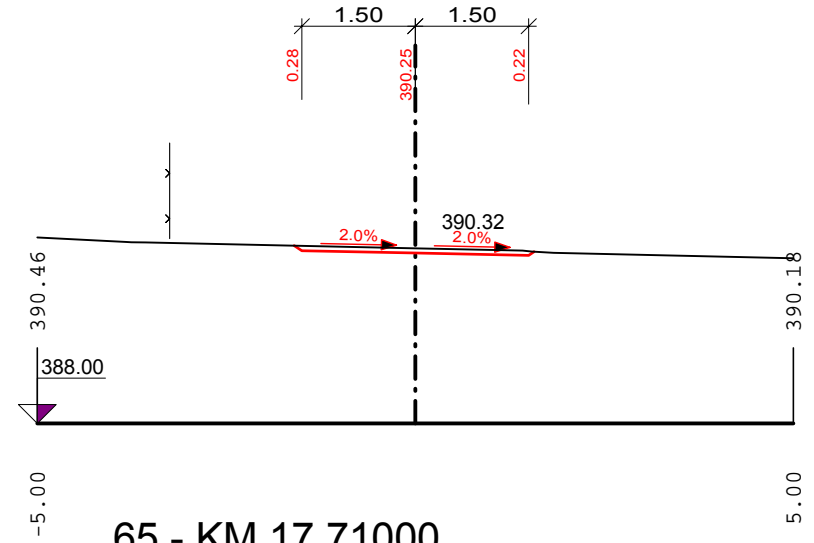

63 - KM 17.66500

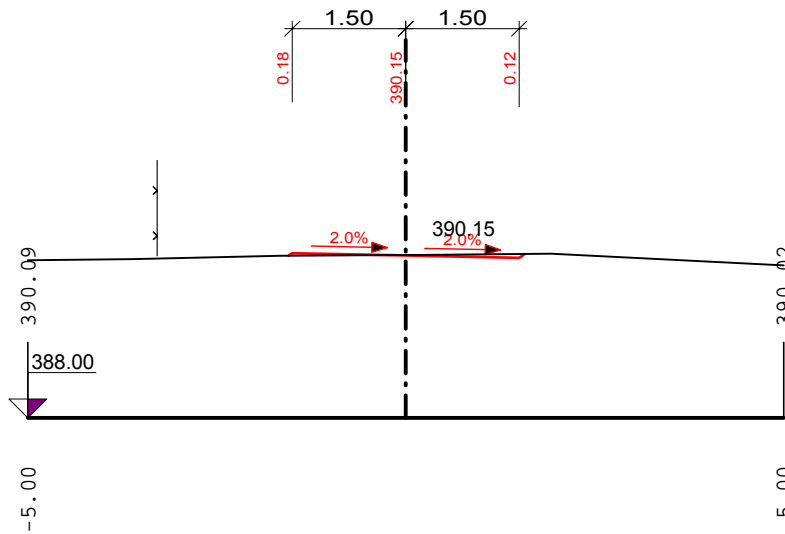

65 - KM 17.71000

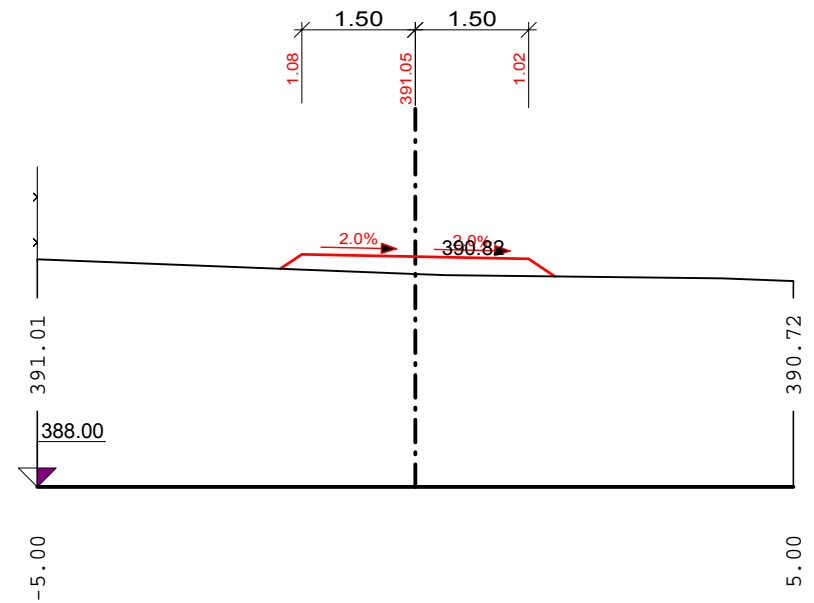

66 - KM 17.73600

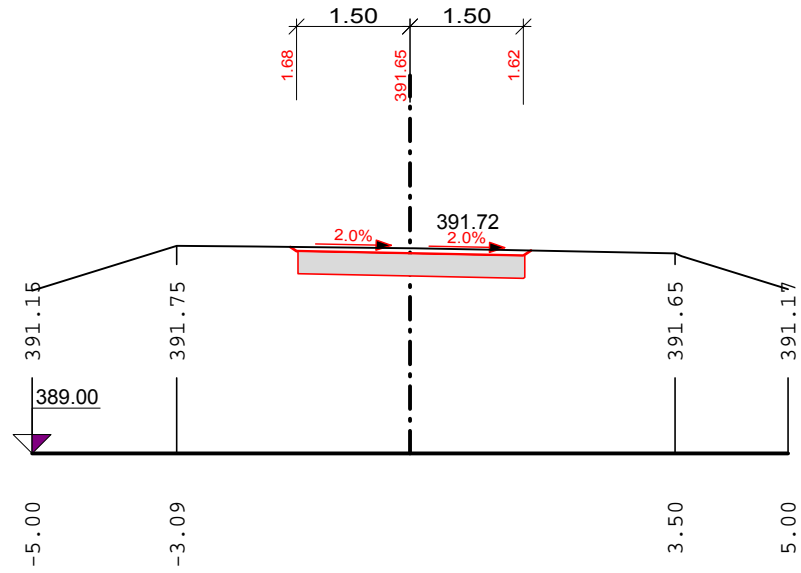

67 - KM 17.75000

